

# gasQS static

## User Manual



The innovative gasQS™ technology is intellectual property of Mems AG.  
Since 2014 gasQS is a registered trade mark.

**WARNING!** Please read the safety instructions carefully before installing and operating the instrument.  
Nonobservance of those guidelines could result in personal injury and/or damage to the equipment.

Even though care has been taken in the preparation and publication of the content of this manual, we do not assume legal or other liability for any inaccuracy, mistake, misstatement or any other error of whatsoever nature contained herein. The material in this manual is intended for information purposes only and is subject to change without notice.

Mems AG  
July 2023

Current terms and conditions apply. Details are available on [www.mems.ch](http://www.mems.ch)

Document Name: 2025-11-07\_gasQS\_static\_UserManual\_en.docx  
Document Number: 202006290928FK  
Last Update: 2025-11-07; Thomas Kleiner

# Contents

General Information .....	4
Aim of Document .....	4
gasQS™ Technology .....	4
gasQS static .....	4
Explanation of Symbols used in this Document .....	5
Certification for Hazardous Areas .....	6
Product Labelling .....	8
Electrical Parameter .....	9
Pressure Parameter .....	9
Maximum Surface Temperatures .....	9
Transport, Packaging and Storage .....	10
Instrument Preparation and Operation .....	11
General Warnings .....	11
Skilled Personnel .....	12
Installation .....	13
Electrical Connection .....	17
Required Material .....	17
Electrical Connection Diagram (Pepperl+Fuchs) .....	18
Electrical Connection Diagram (STAHL) .....	19
Operation .....	22
Maintenance .....	23
General .....	23
Calibration .....	23
Disposal .....	23
Troubleshooting .....	24

# General Information

## Aim of Document

This user manual describes the micro electromechanical, screw-in OEM sensor gasQS static.

For additional information please refer to the following documents:

- **gasQS static Datasheet**
- **gasQS static Safety Instructions**
- **gasQS static Calibration Document**

## gasQS™ Technology

With gasQS, Mems AG provides the technology to use natural gas and biogas in an efficient and environmentally friendly manner.







Natural gas is used in many countries around the world as a source of energy for many years already; its significance will ever more grow in importance in the future. However, power output, efficiency and environmental compatibility of the various gas applications are affected by the ever more rapidly changing gas compositions of new gas sources (biogas, LNG, power-to-gas). The effect of these fluctuations can be compensated and processes optimized through determination of the gas quality – today the domain of expensive process and laboratory analytics.

## gasQS static

The micro electro-mechanical, screw-in OEM sensor- gasQS static - is a solution to analyse gas in an explosive atmosphere. Thermal conductivity is precisely identified, using a micro-thermal sensor. Based on this, different gas parameters (gross heating value, relative density etc.) can be derived for binary gas mixtures (e.g. biogas) with high accuracy. Additionally, the sensor is suitable for multi-component mixtures as long they as are member of the same gas family (e.g. H-gas). Unlike the market standard, this device does not require any readjustment or reference gas.

## Explanation of Symbols used in this Document

Safety symbols in this document are used equal to those in the **gasQS static Safety Instructions**.

	<p><b>Danger</b></p> <p>Indicates an imminently hazardous situation which might result in serious injury or death as well as severe damage to property or equipment, if not followed.</p>
	<p><b>Caution</b></p> <p>Indicates a potentially dangerous situation that can result in light injuries or damage to equipment or the environment, if not followed.</p>
	<p><b>Information</b></p> <p>Points out useful tips, recommendations and information for efficient and trouble-free operation.</p>
	<p><b>ATEX European Explosion Protection Directive</b> (Atmosphère = AT, explosible = EX)</p> <p>Instruments bearing this mark comply with the requirements of the European directive 2014/34/EU (ATEX) on explosion protection.</p>
	<p><b>EX Zone –Hazardous Area with Risk of Explosive Atmosphere</b></p> <p>Marks places which are classified as a potential ATEX zone.</p> <p>Special restrictions or equipment may apply.</p>
	<p><b>CE, Communauté européenne</b></p> <p>Instruments bearing this mark comply with the relevant European directives.</p>

# Certification for Hazardous Areas

Based on the specifications of the casualty insurance SUVA (Schweizerische Unfallversicherungsanstalt) (see Figure 1), the instrument has to be certified for Zone 1 applications. To cover additional customer requirements the instrument reaches Zone 0 standard. Please contact Mems or SUVA for additional information.

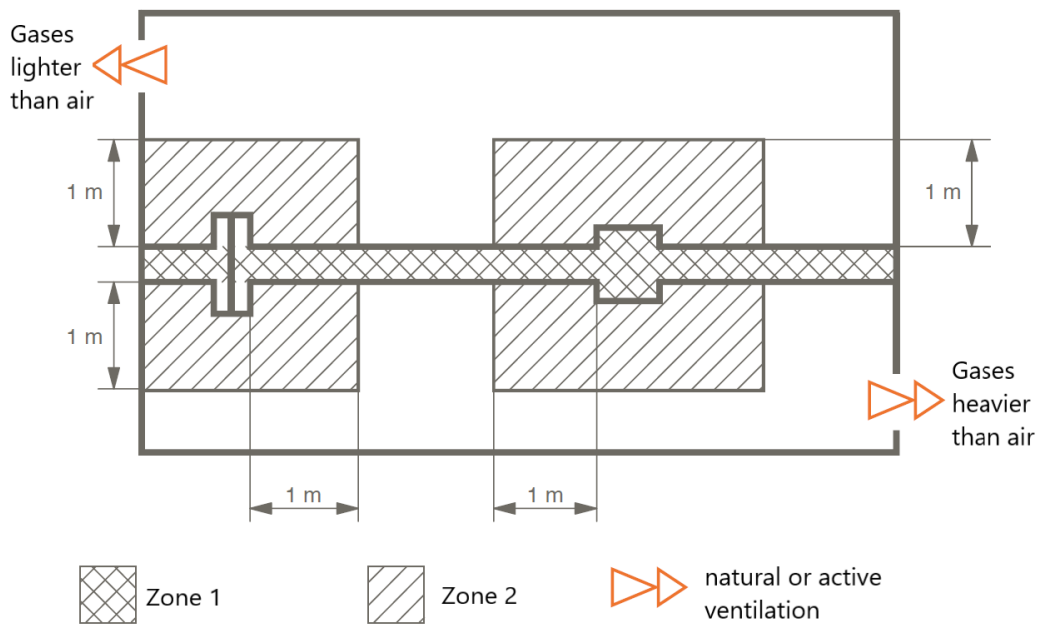



Figure 1: Classification of hazardous area inside a room with a gas line

 <b>DANGER!</b>	<p><b>Safety Barrier</b>                  The instrument has to be connected to a safety barrier. Otherwise it is not suitable for operation inside explosive atmospheres. The safety barrier protects the instrument from interferences of the supply and control system.</p>
	<p><b>Zonal structure of gasQS static application</b>                  The provided safety barrier are NOT certified for applications inside Zone 0 or Zone 1 (see Figure 2). It has to be placed in an environment where an explosive atmosphere is not likely to occur in normal operation and else it may be present for only a brief period of time (see definition of Zone 2 of the engineering standard EN 60079-11).</p>

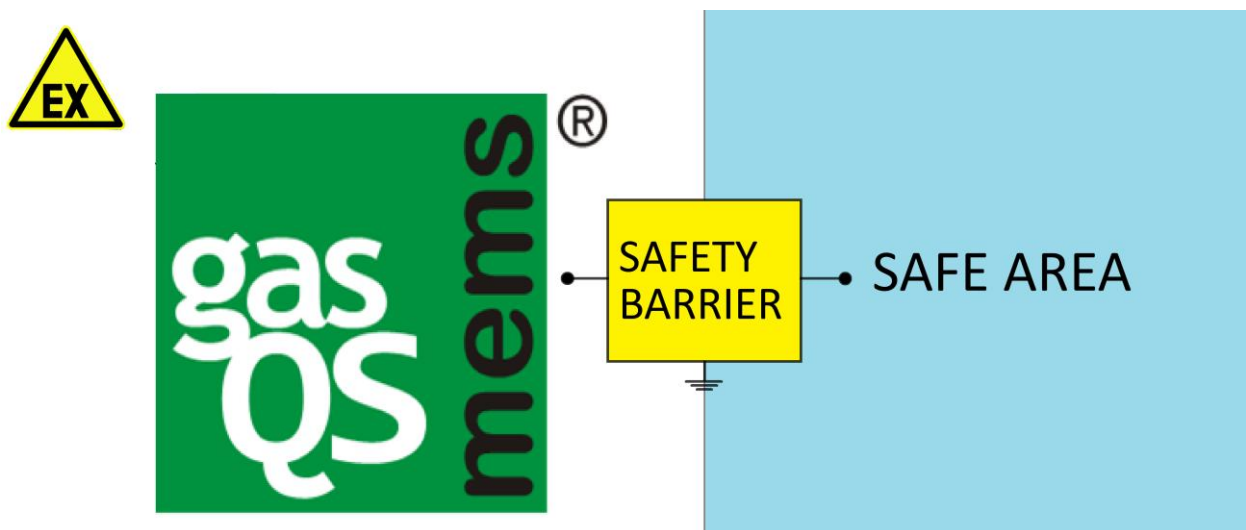

Figure 2: Zonal structure of gasQS static application

# Product Labelling

The instrument fulfils the following type of explosion protection (ATEX / IECEx):

## II 1 G Ex ia IIC T4 Ga

II 1 G: ATEX group and category

ia: intrinsic safe in zone 0

IIC: explosion group with lowest ignition energy (e.g.: Acetylene and Hydrogen)

T4: surface temperature max. 135 °C.

Ga: EN equipment protection level

X: special installation instructions apply for use in the specified zone

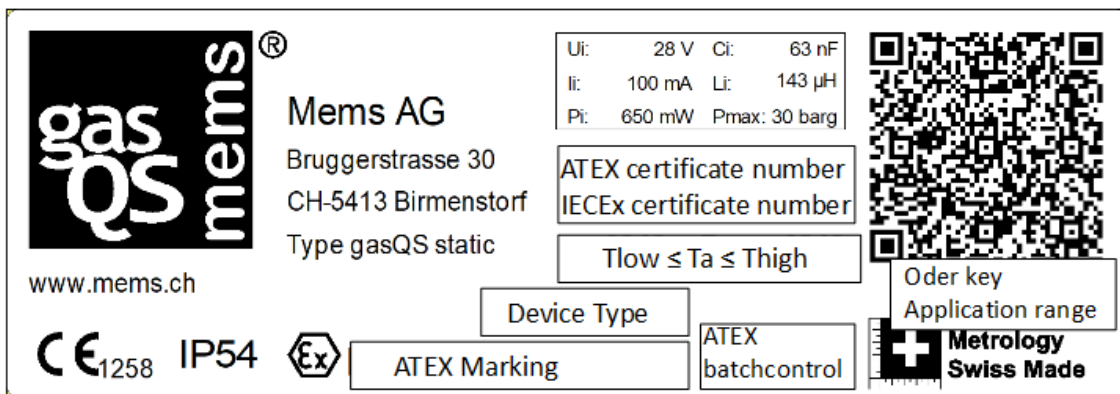





Figure 3: label on instrument

The instrument has been designed and built solely for the intended use described here and may only be used accordingly.

The technical specifications contained in the gasQS static Datasheet must be observed. Improper handling or operation of the instrument outside of its technical specifications requires the instrument to be taken out of service immediately and inspected by an authorised Mems service engineer.



## Transport, Packaging and Storage

 <b>DANGER!</b>	<b>Damaged Material</b> Putting a product which manifests a visible damage into operation can be extremely hazardous. If the product manifests a visible damage stop and make sure it cannot be inadvertently put into use again.
	<b>Skilled Personnel</b> The unit may only be installed by people who have undergone appropriate technical training and possess the necessary experience.
 <b>CAUTION</b>	<b>Check</b> <ul style="list-style-type: none"><li><input type="checkbox"/> Inspect the instrument for possible damage during transportation. Should there be any obvious damage, inform the transport company and Mems without delay.</li></ul>
 <b>Information</b>	<b>Scope of Delivery</b> <ul style="list-style-type: none"><li><input type="checkbox"/> Assembled gas quality instrument; including preassembled sealing and protection cap(s).</li><li><input type="checkbox"/> Keep the packaging, as it offers optimal protection during transportation (e.g. changing installation location, shipment for repair).</li></ul> <b>Protection Cap</b> Enclosed to prevent internal damage or pollution to the instrument during transport and storage. Remove the protection cap(s) only just before installing the instrument to minimise risk of pollution.

# Instrument Preparation and Operation

## General Warnings

The gasQS static must only be used in combination with components (such as measuring cables etc.) approved by MemS. The use of third-party components can affect the safety of the devices and result in significant damages. The devices must only be used by trained and competent personnel. We do not accept liability for damages resulting from the use of third-party components or incorrect handling or operation. The devices must at no time be opened. Do not carry out any service, maintenance or repairs on the instruments. Return instruments to MemS for recalibration or repair.

 <b>DANGER!</b>	<p><b>Appropriate Instrument</b></p> <p>Before installation, commissioning and operation ensure that the appropriate instrument has been selected in terms of measuring range, design and specific measuring conditions. Nonobservance can result in serious injury and/or damage to the equipment.</p>
	<p><b>Escaping Gas</b></p> <p>Escaping gas can lead to serious injury. In the event of failure, components can be ejected at elevated speed or gas exhausted under high pressure.</p> <ul style="list-style-type: none"> <li><input type="checkbox"/> Open the connections only after the system has been depressurised.</li> <li><input type="checkbox"/> Ensure that the pressure in the overall system cannot exceed the lowest maximum pressure of any of its components. If variations of the pressure level or different pressure levels are to be expected in the system, components must be used that can withstand the maximum expected pressure levels and peaks.</li> <li><input type="checkbox"/> Observe the working conditions in accordance with <b>gasQS static Datasheet</b>.</li> <li><input type="checkbox"/> Actions or alterations to the gas quality instrument, which are not described in these operating instructions, are not permitted.</li> <li><input type="checkbox"/> Ensure that the mounting point has been made free from burrs and is clean.</li> <li><input type="checkbox"/> After installation, use a gas leak detector sensitive to the used gas to ensure that there is no leak.</li> </ul>
	<p><b>Safety or Emergency Stop Installation</b></p> <p>Do not use this instrument in safety or emergency stop systems. Incorrect use of the instrument can result in serious injury.</p>



## Skilled Personnel

Skilled personnel have knowledge of measurement and control technology. With their experience and knowledge of country-specific regulations, current standards and directives they are capable of carrying out the work described and independently recognising potential hazards.

 <b>DANGER!</b>	<b>Hazardous Areas</b> Observe the information given in the applicable type examination certificate and the relevant country-specific regulations for installation and use in hazardous areas (e.g. EN 60079-10, EN 60079-14, EN 60079-20). Nonobservance can result in serious injury and/or damage to the equipment.
	<b>Additional Regulations</b> For hazardous media such as flammable gases, in addition to all standard regulations, the appropriate existing codes or regulations must also be followed.
	<b>Skilled Personnel</b> The activities described in these operating instructions may only be carried out by skilled personnel who have the qualifications described above.  Keep unqualified personnel away from hazardous areas.

## Installation

 <p><b>DANGER!</b></p>	<p><b>Improper Mounting</b></p> <p>Improper installation can lead to the loss of the explosion protection and to life-threatening situations.</p> <p>Adhere to the permissible ambient and medium temperatures which are valid for this area based on the specified temperature classes.</p> <p>Protect the instrument from heat sources (e.g. pipes or tanks).</p>
	<p><b>Impact Protection (EX)</b></p> <p>If the instrument is operated in an ATEX zone 0 it must be installed in such a way that it is protected against spark inducing impacts.</p>
	<p><b>Appropriate Instrument</b></p> <p>Before installation, commissioning and operation ensure that the appropriate instrument has been selected in terms of measuring range, design and specific measuring conditions. Nonobservance can result in serious injury and/or damage to the equipment.</p>
	<p><b>Hazardous Areas</b></p> <p>Observe the information given in the applicable type examination certificate and the relevant country-specific regulations for installation and use in hazardous areas (e.g. EN 60079-10, EN 60079-14). Nonobservance can result in serious injury and/or damage to the equipment.</p> <p>Reduce the risk of creating hazardous areas by controlling and monitoring the gas release in relation to the properties of the specific media (e.g. EN 60079-20).</p>

 <b>DANGER!</b>	<p><b>Escaping Gas</b></p> <p>In the event of failure, components can be ejected at elevated speed or gas exhausted under high pressure.</p> <ul style="list-style-type: none"><li><input type="checkbox"/> Ensure that the pressure in the overall system cannot exceed the lowest maximum pressure of any of its components. If variations of the pressure level or different pressure levels are to be expected in the system, components must be used that can withstand the maximum expected pressure levels and peaks.</li><li><input type="checkbox"/> Ensure that the mounting point has been made free from burrs and is clean.</li><li><input type="checkbox"/> After installation, use a gas leak detector sensitive to the used gas to ensure that there is no leak.</li></ul>
 <b>CAUTION!</b>	<p><b>Calibration</b></p> <p>Make sure that the device to be installed has been calibrated for the type of gas present in the system. Nonobservance not only could lead to possible damage due to erroneous process control value but even hazardous situations could emerge.</p>
 <b>Information</b>	<p><b>Controlled Gas Release</b></p> <p>The thread on the head of gasQS static instrument is directly attached to a gas line or tank. However, it does not affect the way it is mounted.</p> <p><b>Reaction Time</b></p> <p>The reaction time of the instrument is strongly dependent from the distance between sensor and gas line. MemS recommends a process connection that ensures a distance not longer than 1 cm from the gas line. Doubling the distance results in a quadrupled latency.</p>
	<p><b>Pollution and Abrasion</b></p>

 <p><b>CAUTION!</b></p>	<p>Make sure there is no pollution inside the sensor in- and outlet before connecting the instrument. Do <b>NOT</b> use any lubricant or sealant. Abrasion can damage or even destroy the sensor.</p>
	<p><b>Mechanical Stress, Liquids and Dirt</b></p> <p>Do <b>NOT</b> insert any item into the opening in front of the instrument. Mechanical stress, liquids and dirt may damage or destroy the sensor. Warranty excludes failures and damage caused by the customer, such as contamination, improper electrical hook-up, dropping etc.</p>
	<p><b>Mounting Position</b></p> <p>The instrument has to be mounted in an <b>upright position</b> (see Figure 4). Dirt in the gas pipe could otherwise damage or even destroy the sensor.</p> <p>If this is not observed, the specified measuring performance cannot be guaranteed.</p>

 <p><b>Information</b></p>	<p><b>Ensure Inline Condition</b></p> <ul style="list-style-type: none"> <li><input type="checkbox"/> upright installation</li> <li><input type="checkbox"/> dry gas</li> <li><input type="checkbox"/> dew point of the gas mixture at least 10 K lower than the lowest operating temperature</li> </ul>
---	--

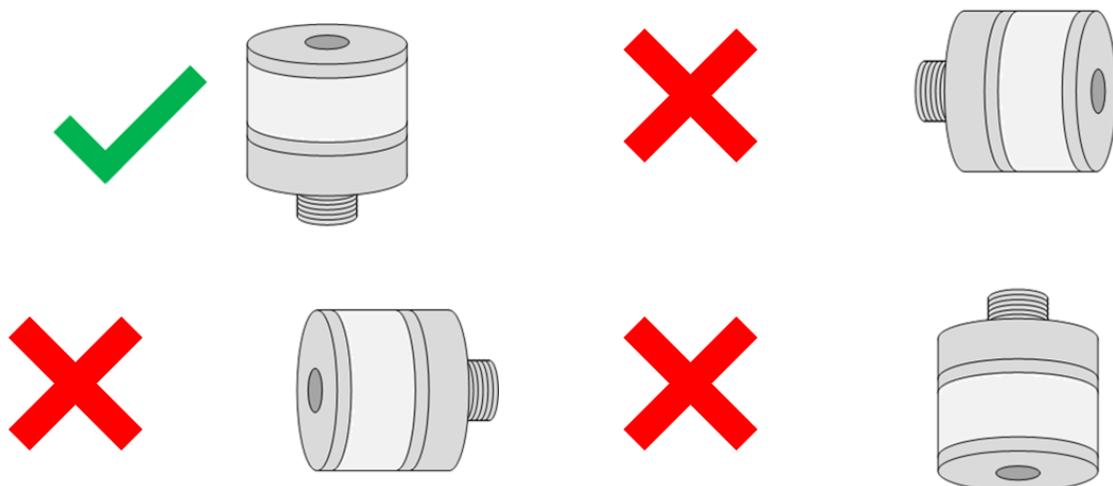



Figure 4: mounting position

*The connection between instrument and gas line is sealed by a d18x2mm NBR70 O-ring.*

 <b>CAUTION!</b>	<b>Abrasion</b> Do not use any lubricant or sealant. Abrasion can damage or even destroy the sensor.
	<b>Maximum Torque</b> To avoid mechanical damage, please make sure to never drive more than 10 Nm torque on instruments thread.

## Electrical Connection

### Required Material

- gasQS static instrument
- Safety barrier for ATEX applications
- Power supply (+24 Vdc  $\pm 10\%$ )
- Amperemeter

The 4-20 mA interface is the most common setup for the gasQS static instrument. For use in hazardous areas, the instrument must be connected to a safety barrier. The customer has to add a +24 Vdc supply and an amperemeter to measure the output of the instrument. Please attach the parts as described in the following block diagram (see Figure 5).

If the instrument is used in a safe zone, the positive connection of the power supply can be connected directly to line number 1. The current is measured between line number 2 and GND of the power supply. ATTENTION, the current measurement must be isolated from earth (see Figure 7).

### Connector pin assignment

#### gasQS static

M12-B 5-pol, male + shield

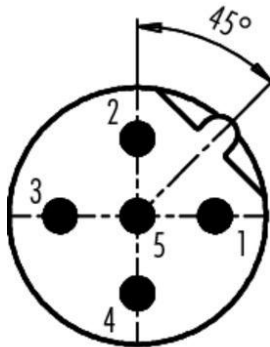

#### Signal 4 ... 20 mA

M12-B 5-pol, female + shield

1	-
2	-
3	-
4	V+
5	V-
shell	shield

Electrical Connection Diagram (Pepperl+Fuchs)

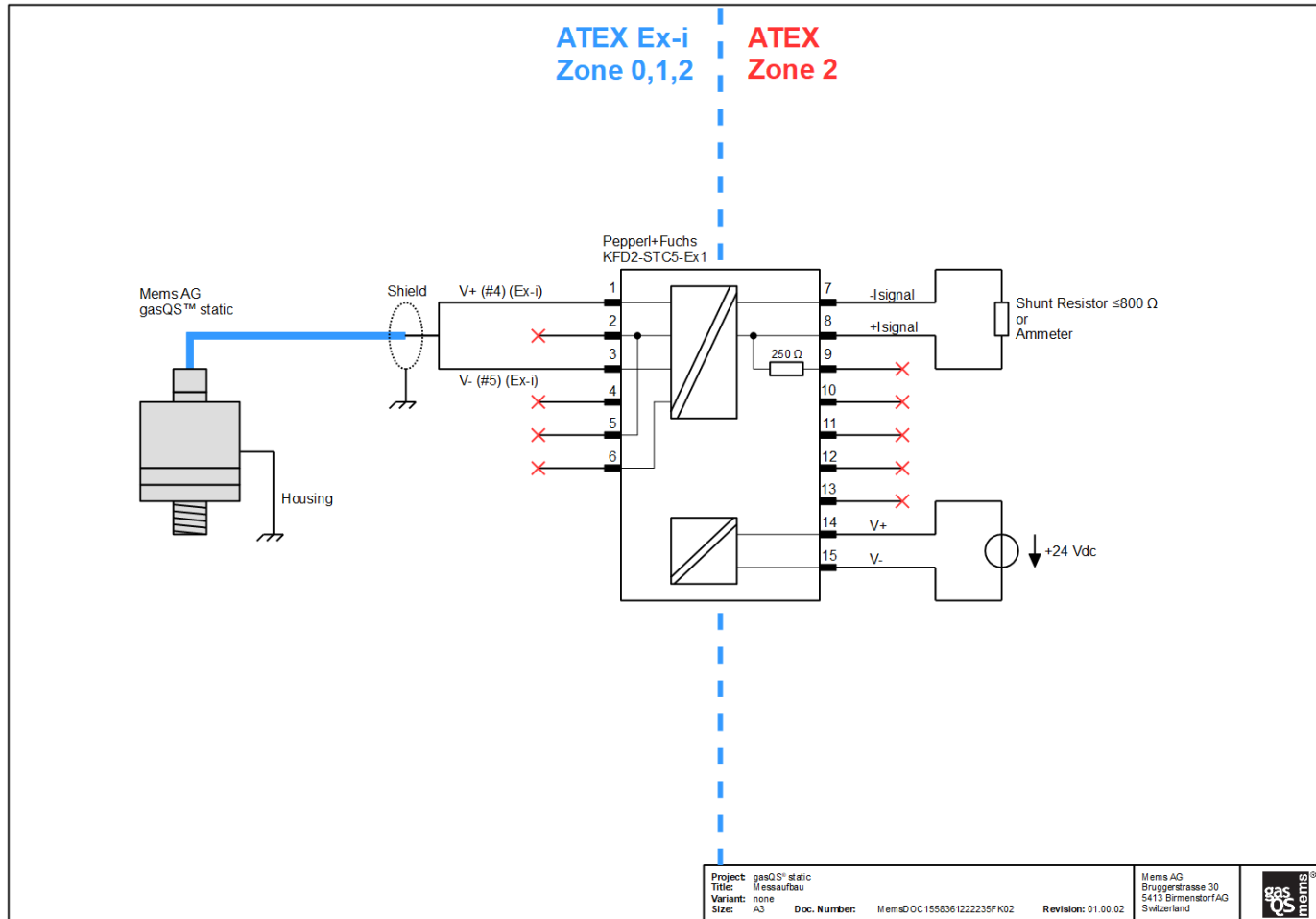

Figure 5: Electrical connection diagram 4-20 mA Pepperl+Fuchs

Electrical Connection Diagram (STAHL)

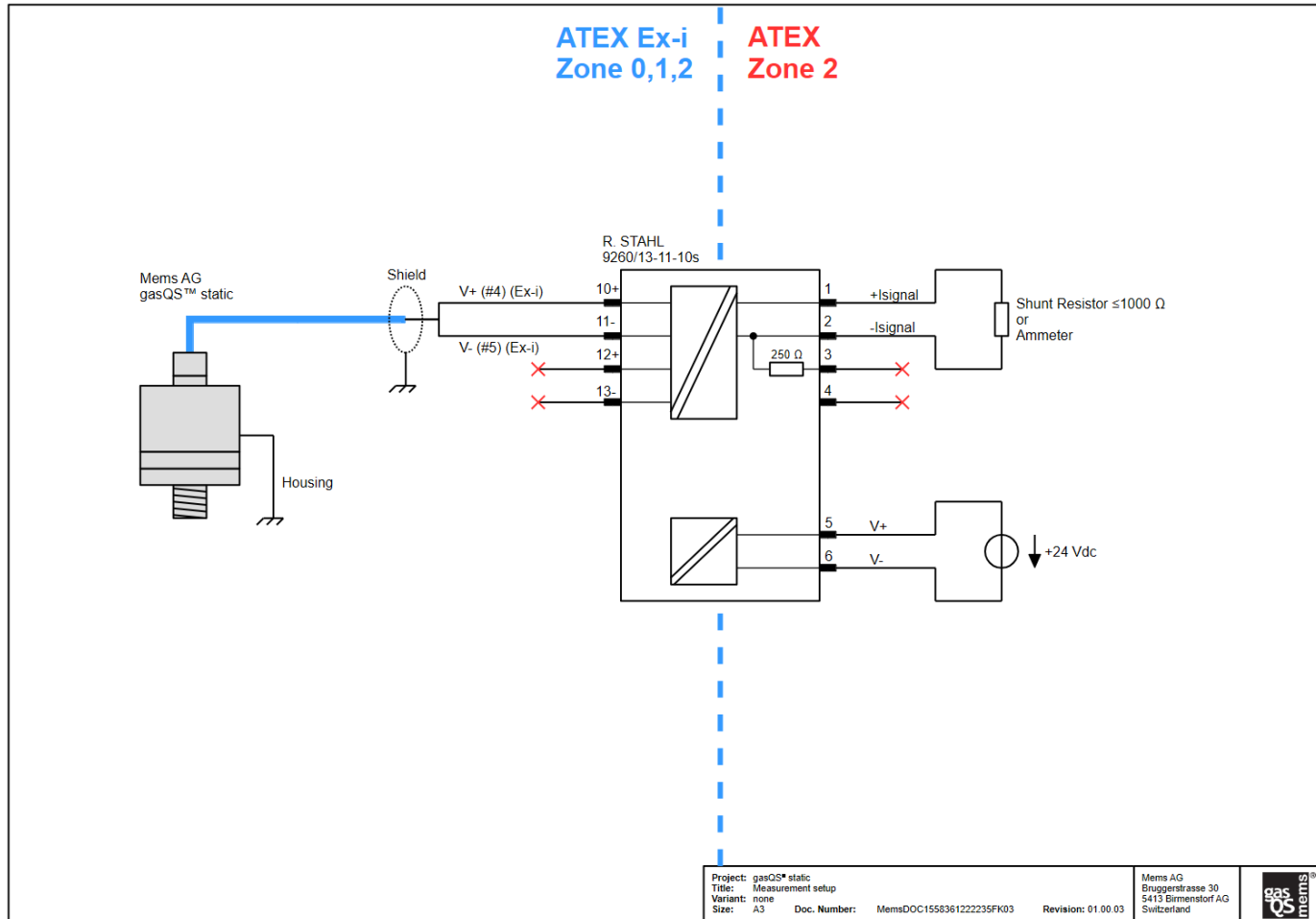

Figure 6: Electrical connection diagram 4-20 mA STAHL

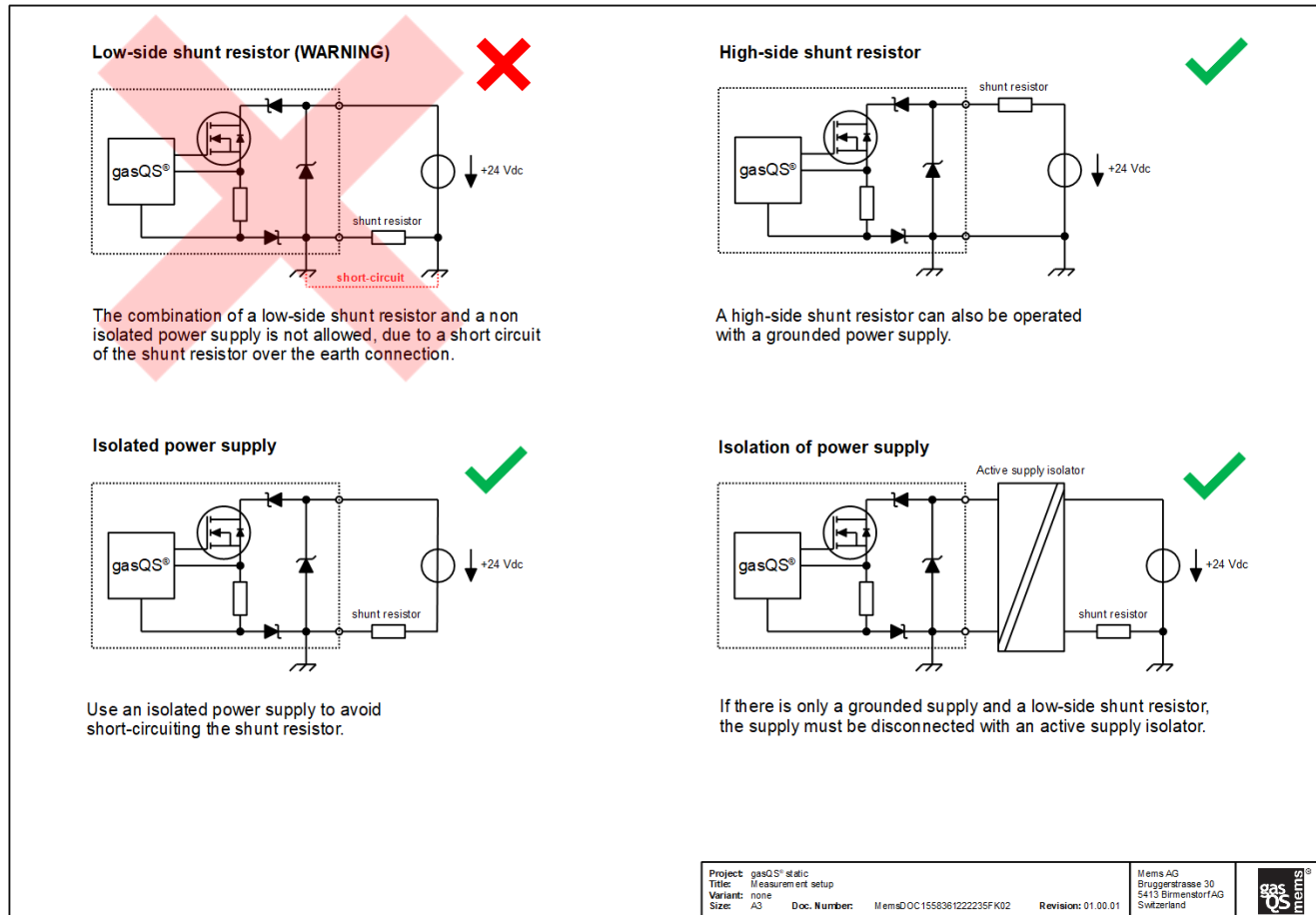





Figure 7: Electrical Measurement Setup

 <p><b>DANGER!</b></p>	<p><b>Electrical Connections</b></p> <p>For installation in hazardous areas ensure that the enclosure is potentially equalized.</p> <p>To increase interference immunity, Mems AG recommends connecting the shield of the cable to earth at both ends. Attention for applications in hazardous areas, it must be ensured that potential equalization exists between the various earthing points (i.e. between the hazardous area and safe area). For more information please refer to standard EN 60079-14.</p> <p>Connect the instrument only to intrinsically safe circuits (Ex ia).</p> <p>Cover flying leads with fine wires by an end splice (cable preparation).</p>
	<p><b>Supply Voltage</b></p> <p>Ensure that supplied voltage adheres to the specified electrical characteristics and never exceeds the maximum limit.</p>
	<p><b>Cable Modifications</b></p> <p>Do not shorten, extend or replace the provided cable without consultation of an authorized Mems service engineer.</p>
 <p><b>CAUTION!</b></p>	<p><b>Electrostatic Discharge (ESD)</b></p> <p>ESD can damage equipment, impair electrical circuitry and can result in complete or intermittent failures. Always place the protective caps on the connector when they are not used and do not touch the connector pins.</p>

## Operation

 <p><b>DANGER!</b></p>	<p><b>Power Off</b> Do not separate when energized.</p>
---	---

 <p><b>Information</b></p>	<p><b>Moving Average</b> If the current measurement is done by a digital system like a PLC (Programmable Logic Controller), MemS recommends smoothing the signal with a moving average of 64 points or more.</p>
---	--

The instrument starts measuring as soon as it is connected to the power supply. There is no need for any additional interaction. The interpretation of the current output depends on the calibration made for this instrument. Please see the calibration documentation delivered with the instrument.

# Maintenance

## General

 <b>DANGER!</b>	<p><b>Power Off</b> Do <b>NOT</b> separate when energized.</p> <p>Power supply <b>MUST</b> be switched off and disconnected at main <b>BEFORE</b> cleaning or repair.</p>
	<p><b>Pressurized Connections</b> Do <b>NOT</b> open pressurized connections.</p>

 <b>Information</b>	<p><b>Maintenance and Repairs</b> At normal use, no routine maintenance is required to be performed on the instrument. For further information contact supplier or factory. Have repairs performed by the manufacturer only to prevent losing warranty claim.</p>
--	---

## Calibration

 <b>Information</b>	<p><b>Factory Calibrated</b> The instrument is factory calibrated. Please contact supplier or factory for re-calibration or re-ranging.</p>
---	---

## Disposal

 <b>Information</b>	<p><b>Disposal</b> Dispose of instrument components and packaging materials in accordance with the respective waste treatment and disposal regulations of the region or country to which the instrument is supplied.</p>
---	--

# Troubleshooting

 <b>DANGER!</b>	<b>Pressurized Connections</b> Open pressurized connections only after the pressure of the system or the appropriate section has been released to atmospheric level.
	<b>Damaged Instruments</b> Instantly remove the instrument from service and mark it to prevent accidental usage if it becomes damaged or unsafe for operation.  Have repairs performed by the manufacturer only.

 <b>Information</b>	<b>Common Source of Failure</b> Please verify in advance if the correct supply voltage and wiring has been chosen.
	<b>Cleaning</b> Do not insert any pointed or hard objects into the pressure ports for cleaning to prevent damage to the sensor of the pressure connection.

Failure	Possible cause	Procedure
<b>No output signal</b>	No/incorrect voltage supply	Adjust the voltage supply to correspond with the Operating Instructions *)
	Cable break / connection loss	Check connections and cable
<b>Output signal diverges from expected value</b>	Instrument is not calibrated for used gas mixture.	Check documentation
	Residual gas inside the instrument or its inlet pipe	Make sure that the pipe is purged completely with new gas mixture.  Check distance between sensor and gas line.
	Instrument is not mounted in upright position.	Put installation out of operation and mount instrument as described in chapter Installation.
	Micro-thermal sensor is damaged.	Contact the manufacturer
<b>Output value under 4mA</b>	Earth fault in the current measurement.	Check page 20 Contact the manufacturer
<b>Reaction time is longer than specified</b>	Distance between instrument and gas pipe is too long.	Put installation out of operation and reduce inlet pipe as much as possible. (see chapter Installation)

In case of unjustified reclamation, we may charge a reclamation handling expense.

\* Make sure that after the setting of the unit is working properly. In case the error continues to exist send in the instrument for reparation (or replace the unit).